

8

7

6

5

4

3

2

1

D

D

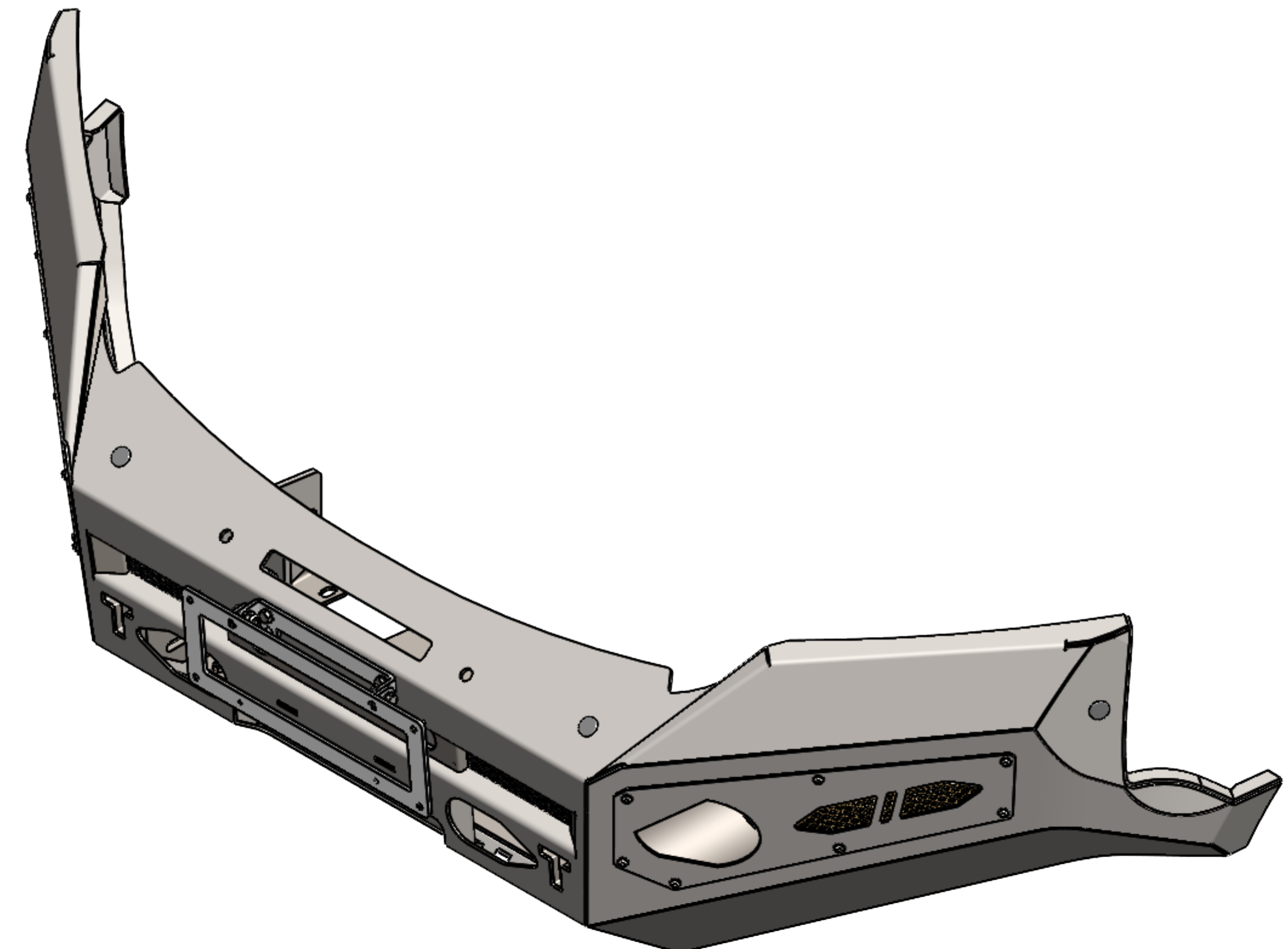
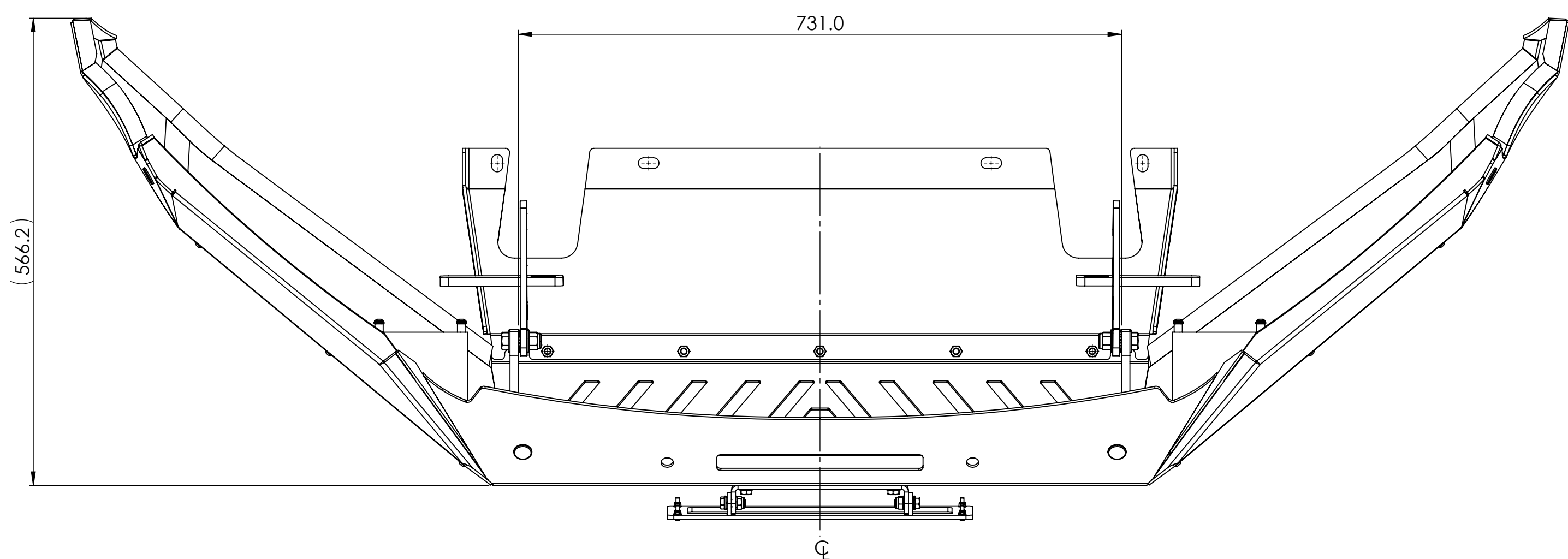

C

C

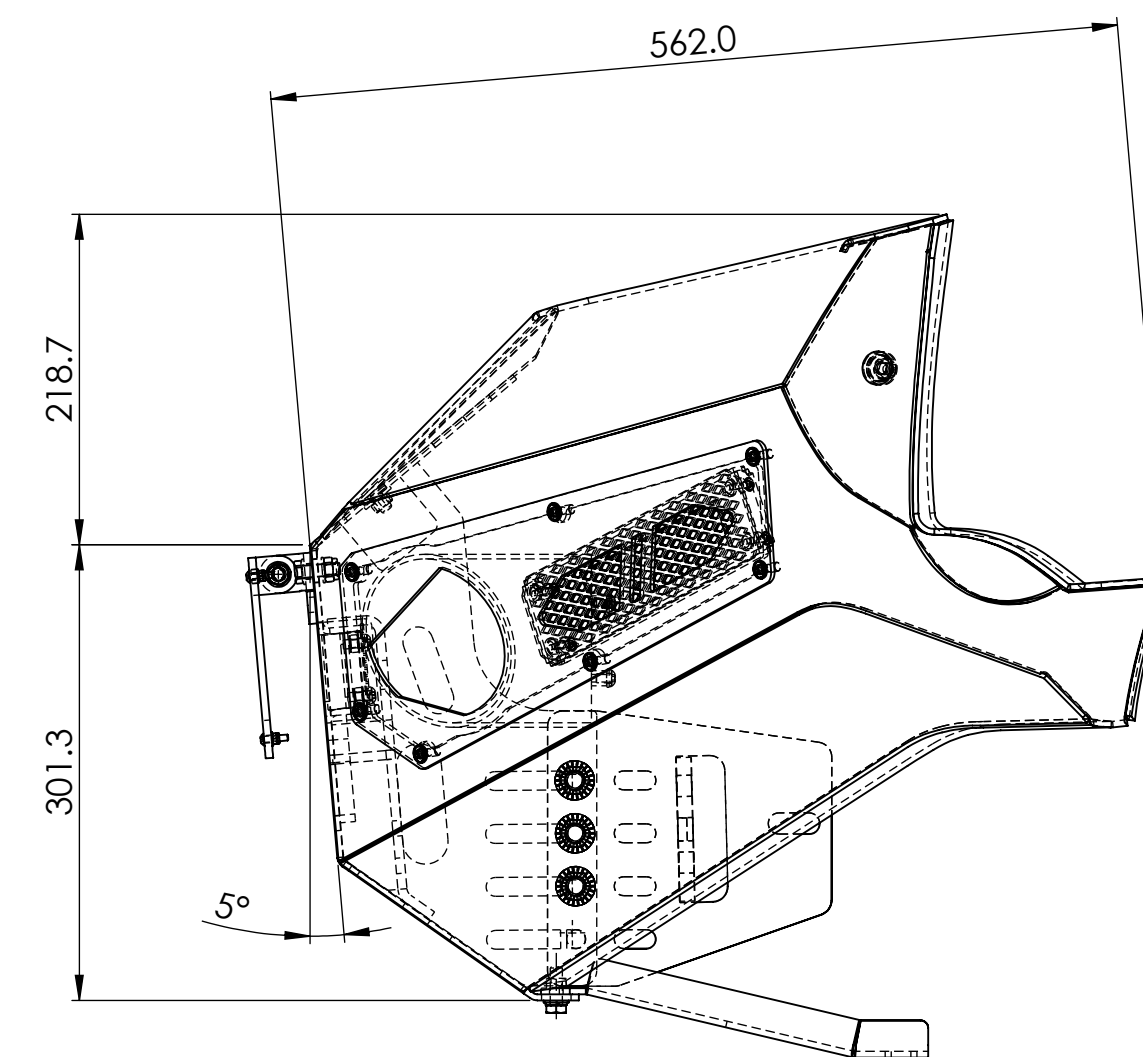
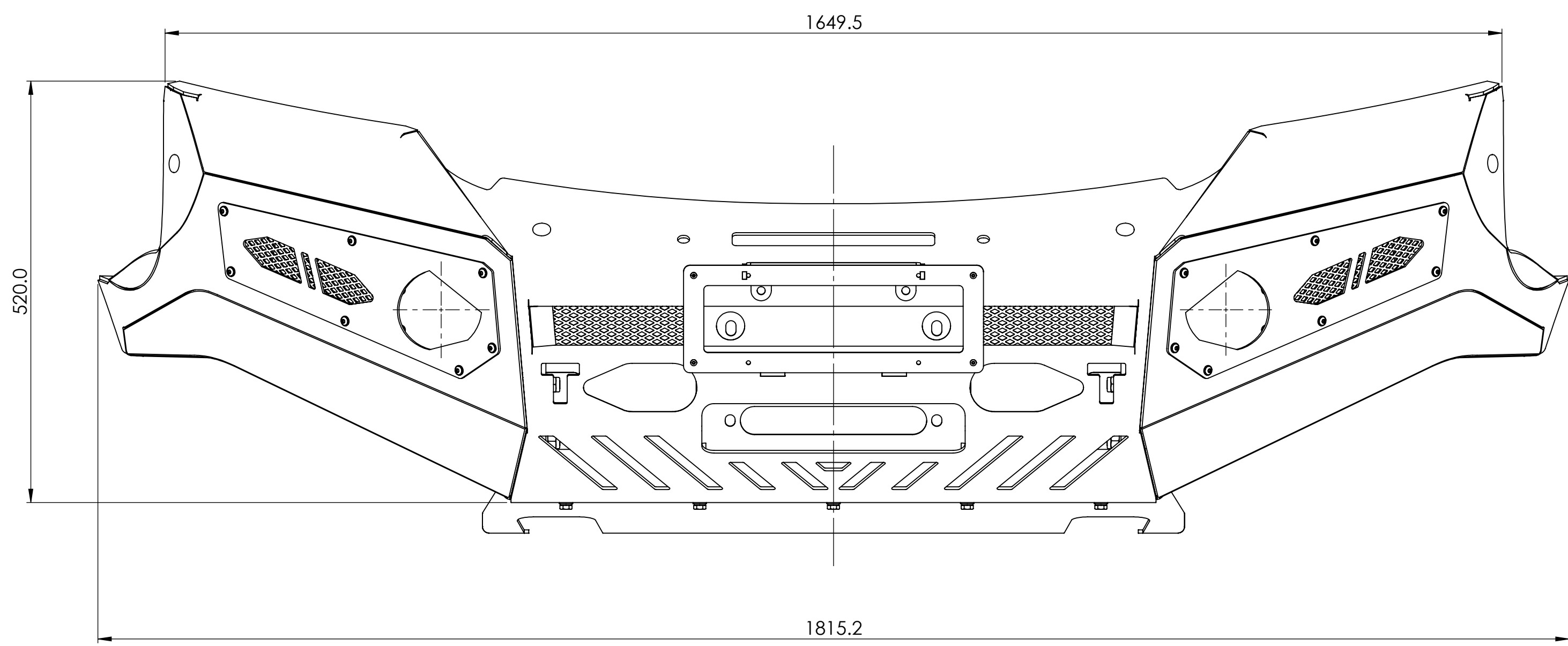

B

B

A

A

This drawing and all the information thereon remains the property of CADmine and shall be returned on demand. It is issued on the condition that, except with written permission, it must not be reproduced, copied, or communicated to any party, nor to be used for any other purpose than that stated on the particular enquiry, order, or contract with which it was issued. Acceptance of this drawing signifies acceptance of the above conditions and copyright.

TOLERANCE ON DIMENSIONS UNLESS NOTED OTHERWISE

MACHINING

- One Decimal Place : 0.10
- Two Decimal Places : 0.05
- Angular : 0.5°

- Surface Finish : $\frac{NB}{\sqrt{\quad}}$

FABRICATION

- Up To 300 ±1
- 301 To 1000 ±1.5
- 1001 To 3000 ±2
- 3001 To 5000 ±2.5
- Over 5000 ±3
- Angular 1°

DWG No.	TITLE	No.	DESCRIPTION	BY	DATE	CHK	DATE	APP	DATE
	REFERENCE DRAWING		DRAWING REVISIONS						

SIGNED APPROVED

ENG	
DRN	
CHK	
APP	

ORIGINAL DWG SIZE



DRAWN	
CHECKED	
Q.A.	
MFG	
APPROVED	

3RD ANGLE PROJECTION

PROJECT:	1135 COL-18-NH		
TITLE:	COLARADO 2018 BULL BAR - NO HOOP		
WEIGHT =>:	53.03 Kg	SIZE	D
MR:	SEE BOM	DWG. NO.	1135-COL-18-NH
FINISHED:		REV	5
			SHEET 1 OF 1

8

7

6

5

4

3

2

1