

Fasteners Assembly Instructions for GU-PAT-4

Applying for products:

0141-GU-PAT-4-PC-NH / 0141-GU-PAT-4-EXP-NH

0142-GU-PAT-4-PC-SH / 0142-GU-PAT-4-EXP-SH

0143-GU-PAT-4-PC-3H / 0143-GU-PAT-4-EXP-3H

Part number	Description	Qty/per set
AC01	Hex Head Bolt M12 x 40mmL x P1.25	6
AC02	Nyloc Nut M12 x P1.25	6
AC03	Steel Nord Lock Washer M12 x 13mmID x 19mmOD x 2.2mmT	6
AC04	Steel Flat Washer M12 x 13mmID x 26mmOD x 2.2mmT	22
AC05	M6 x 10mmL x P1 Steel Hex socket (allen Key) & Domed Head Bolt	12
AC06	M6 x 12mmL x P1 Steel Hex socket (allen Key) & Domed Head Bolt	8
AC07	Steel Spring Washer M6	8
AC08	Steel Flat Washer M6 x 6.6mmID x 15mmOD x 2mmT	8
AC09	M4 x 15mmL x P0.7 Hex socket (allen Key) & Domed Head Bolt	10
AC10	Steel Flat Washer M4 x 4.3mmID x 9mmOD x 0.8mmT	12
AC11	Nyloc Nut M4 x P0.7	2
AC12	Hex Head Bolt M12 x 50mmL x P1.25 - Haft theard27mm Zinc	2
AC13	Steel Spring Washer M12	2
AC15	Hex Head Bolt M16 x 50mmL x P 2	2
AC16	Steel Flat Washer M16 x 17mmID x 30mmOD x 2.5mmT	4
AC17	Hex Head Bolt M16 x 30mmL x P 2	4
AC30	Electric Cable Packed	1
AC31	Frog Lights (Pair) with Accessories	1
AC32	Indicator Lights (Pair)	1

GENERAL VIEW

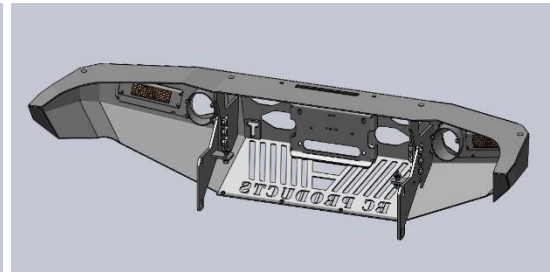
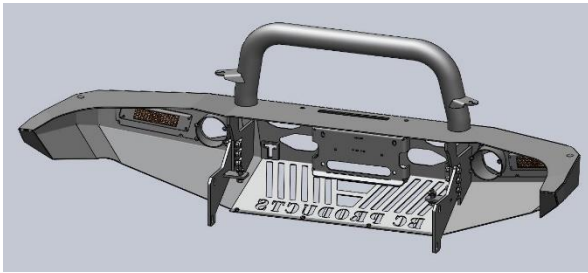
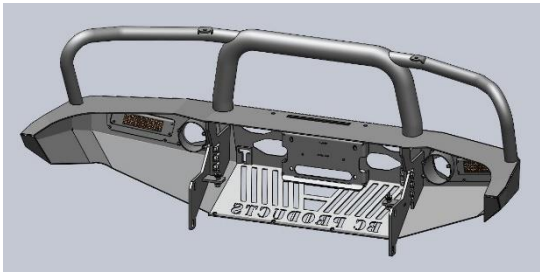
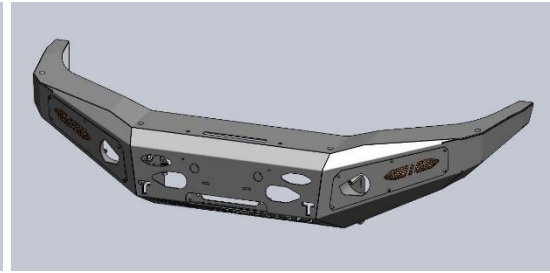
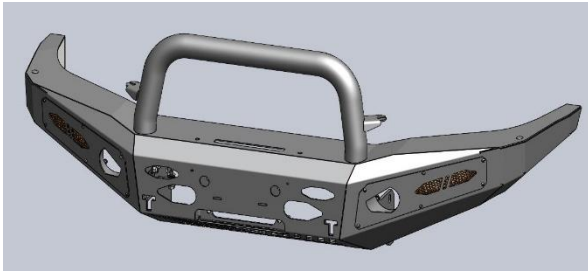
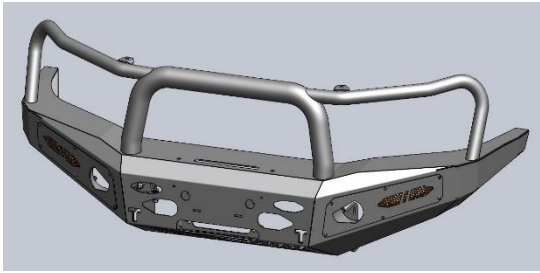

3 HOOP

SINGLE HOOP

NO HOOP

WI-006-R2

STEP 1: Install Brackets into the Car, bolted both sides with 2 positions.

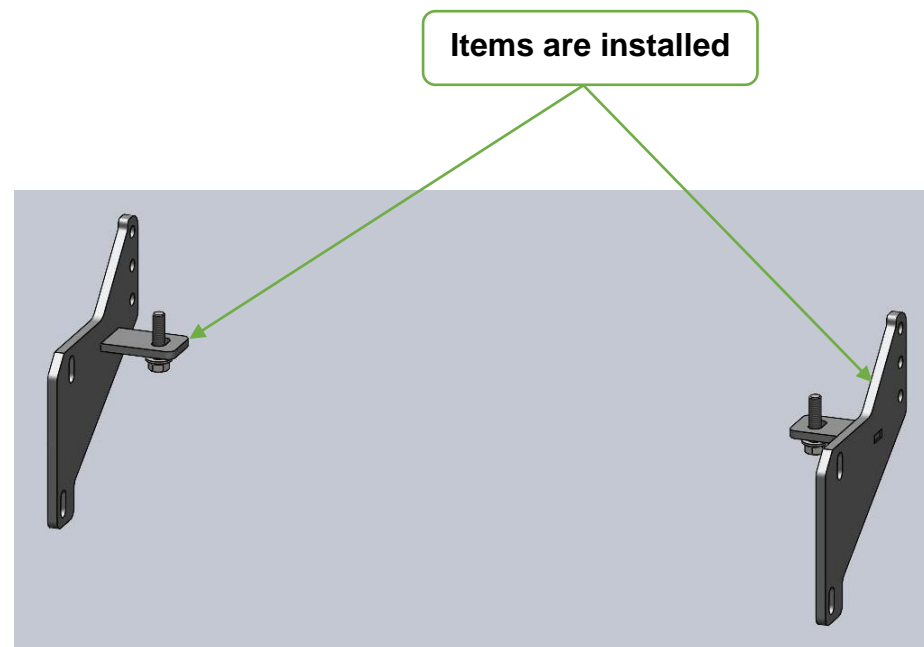
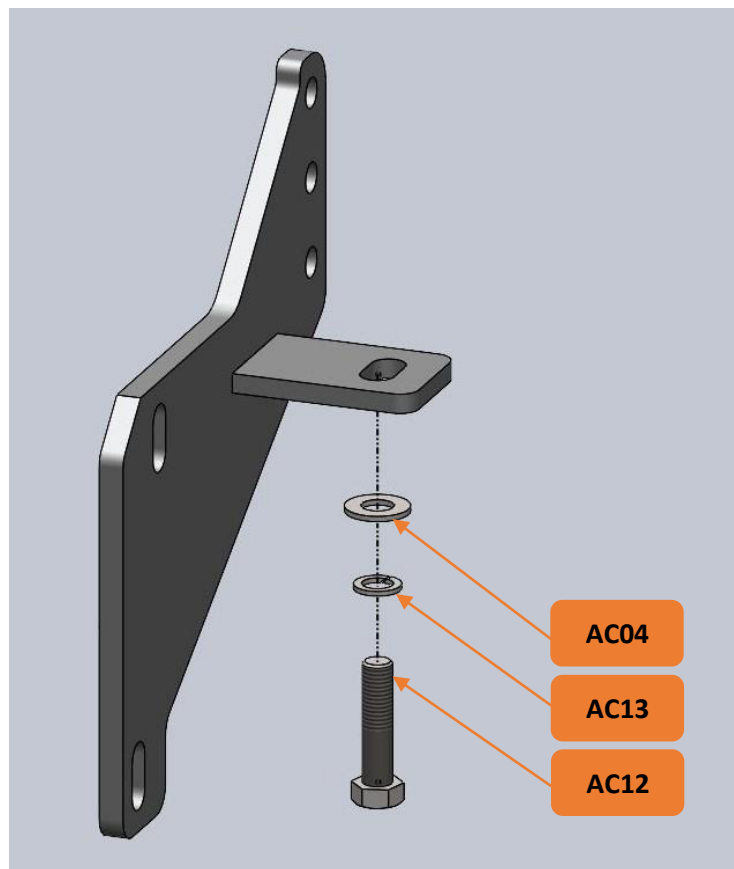

AC04 x 02 pcs : Steel Flat Washer M12 x 13mmID x 26mmOD x 2.2mmT

AC12 x 02 pcs : Hex Head Bolt M12 x 50mmL x P1.25 - Haft theard27mm Zinc

AC13 x 02 pcs : Steel Spring Washer M12

Bolt Tightening Torque: 88(Nm)

WI-006-R2

STEP 2: Install Bull Bar Body into the Car, bolted both sides with 6 positions.

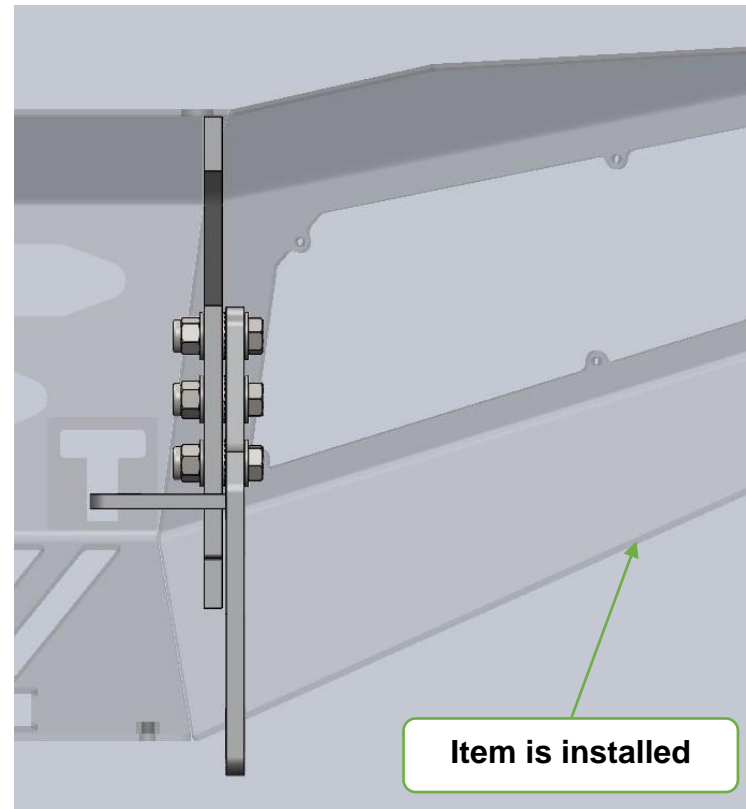
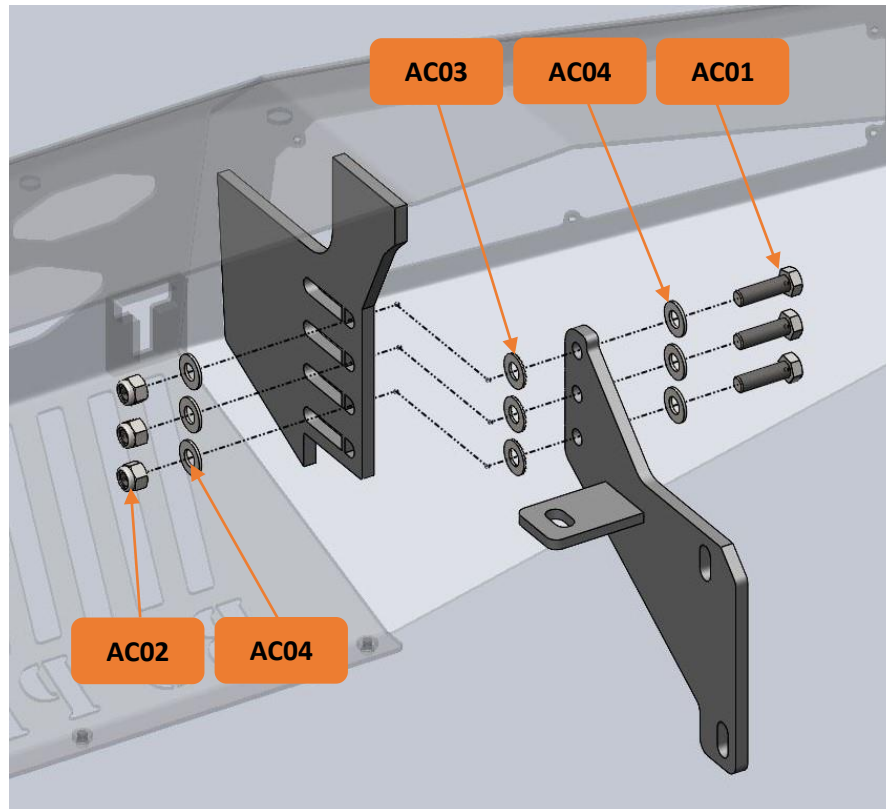

AC01 x 06 pcs : Hex Head Bolt M12 x 40mmL x P1.25

AC02 x 06 pcs : Nyloc Nut M12 x P1.25

AC03 x 06 pcs : Steel Nord Lock Washer M12 x 13mmID x 19mmOD x 2.2mmT

AC04 x 12 pcs : Steel Flat Washer M12 x 13mmID x 26mmOD x 2.2mmT

Bolt Tightening Torque: 88(Nm)

WI-006-R2

STEP 3.1: Install 3 Hoop into the Car, bolted with 4 positions. **[Use for 3 Hoop only]**

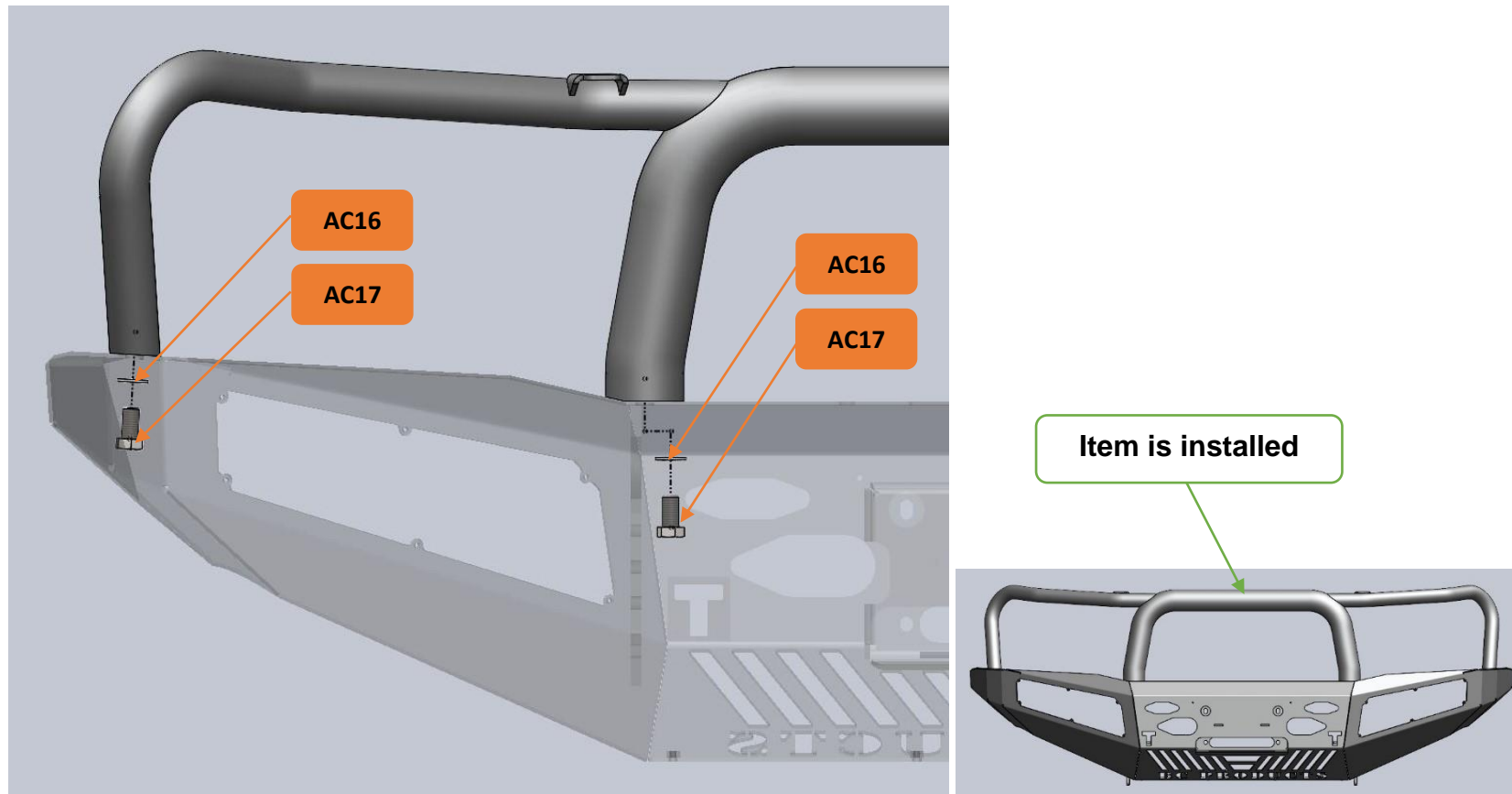

AC16 x 04 pcs : Steel Flat Washer M16 x 17mmID x 30mmOD x 2.5mmT

AC17 x 04 pcs : Hex Head Bolt M16 x 30mmL x P 2

Bolt Tightening Torque: 88(Nm)

WI-006-R2

STEP 3.2: Install Single Hoop & Plastic Cap into the Car, bolted with 4 positions. **[Use for Single Hoop only]**

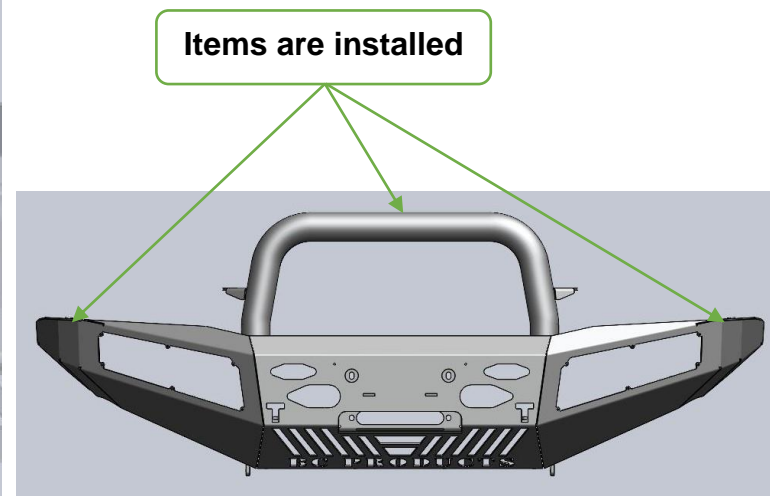
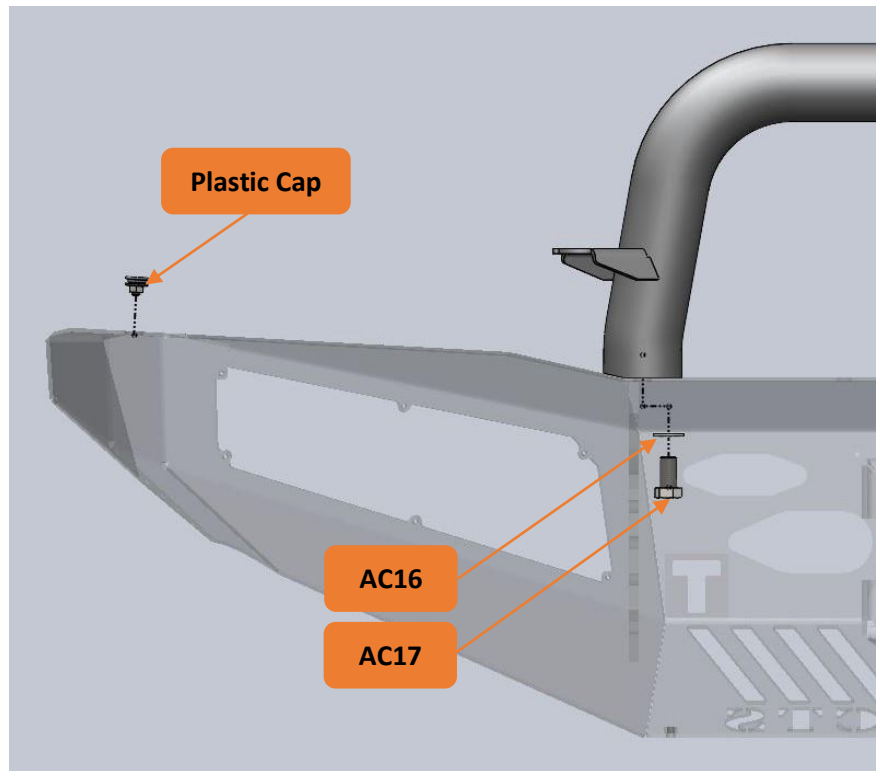

Plastic Cap x 02 pcs

Bolt Tightening Torque: 3(Nm)

AC16 x 02 pcs : Steel Flat Washer M16 x 17mmID x 30mmOD x 2.5mmT

AC17 x 02 pcs : Hex Head Bolt M16 x 30mmL x P 2

Bolt Tightening Torque: 88(Nm)

WI-006-R2

STEP 3.3: Install Plastic Cap into the Car, bolted with 4 positions. [Use for No Hoop only]

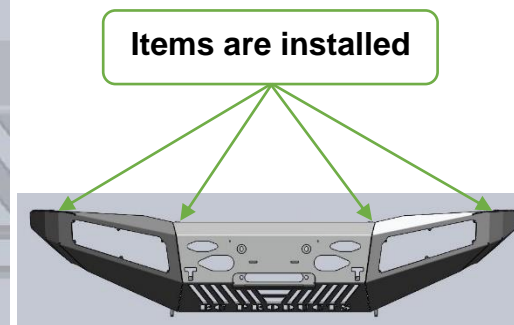
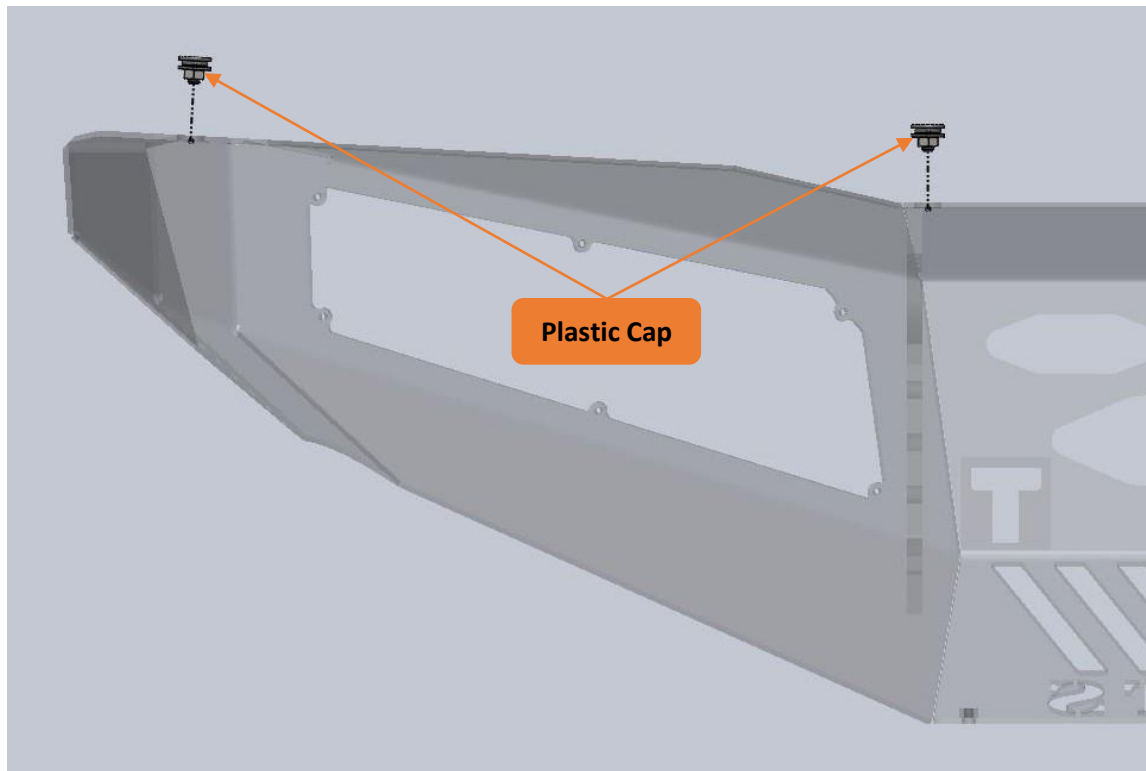

Plastic Cap x 04 pcs

Bolt Tightening Torque: 3(Nm)

WI-006-R2

STEP 4.1: Install Frog Light into Light Panel LH & RH, bolted both side with 8 positions.

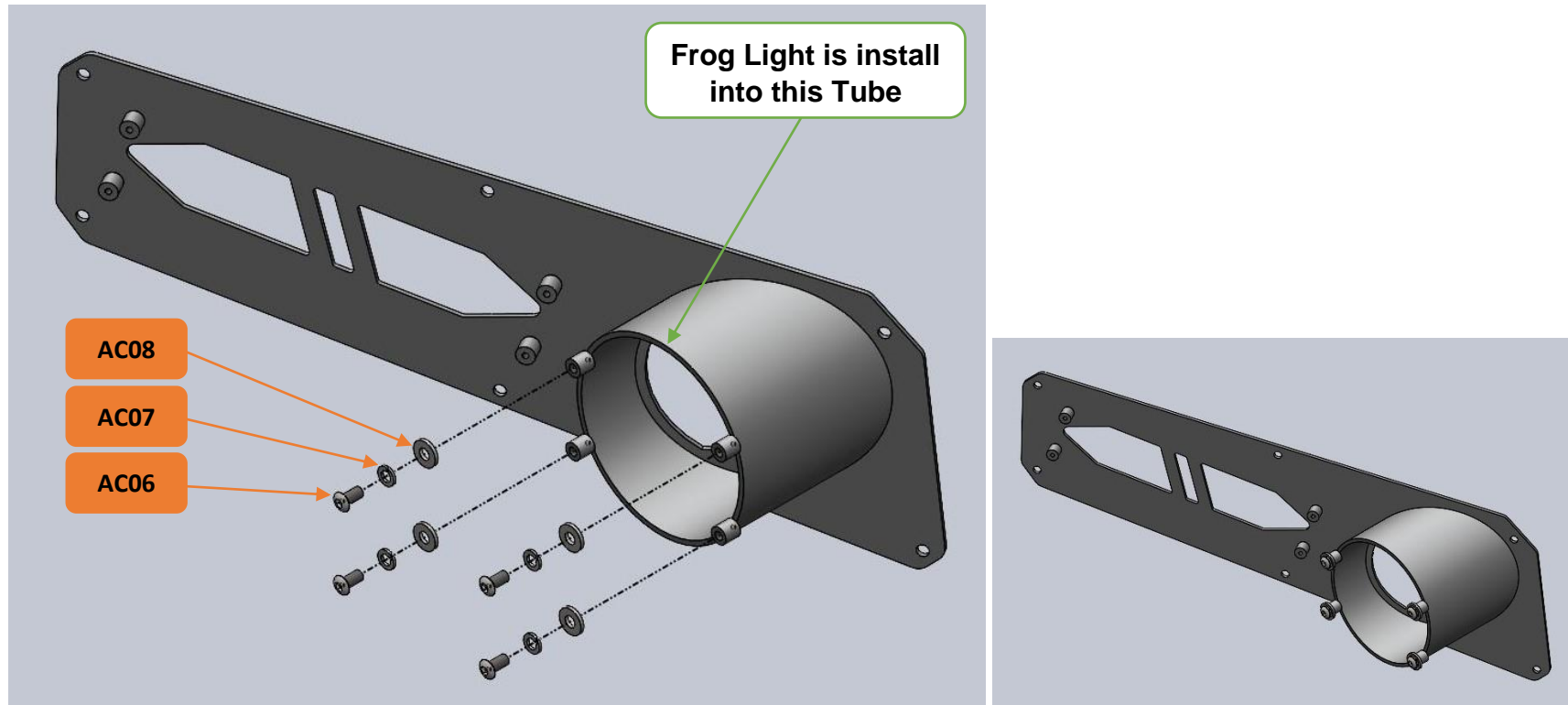

AC31 x 01 pcs : Frog Lights (Pair) with Accessories

AC06 x 08 pcs : M6 x 12mmL x P1 Steel Hex socket (allen Key) & Domed Head Bolt

AC07 x 08 pcs : Steel Spring Washer M6

AC08 x 08 pcs : Steel Flat Washer M6 x 6.6mmID x 15mmOD x 2mmT

Bolt Tightening Torque: 10(Nm)

WI-006-R2

STEP 4.2: Install Indicator Light into Light Panel LH & RH, bolted both side with 8 positions.

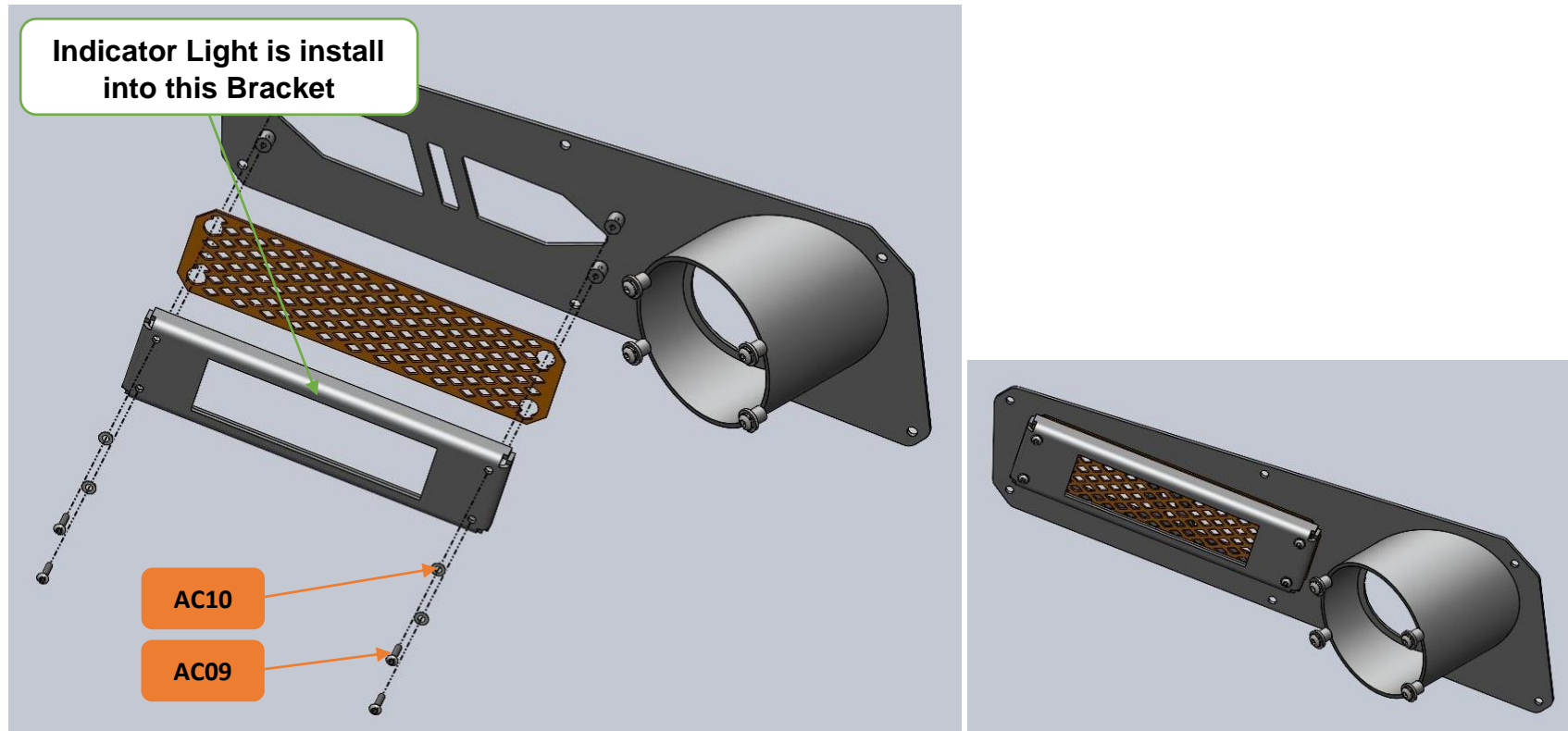

AC32 x 01 pcs : Indicator Lights (Pair)

AC09 x 08 pcs : M4 x 15mmL x P0.7 Hex socket (allen Key) & Domed Head BoltT

AC10 x 08 pcs : Steel Flat Washer M4 x 4.3mmID x 9mmOD x 0.8mmT

Bolt Tightening Torque: 3(Nm)

WI-006-R2

STEP 4.3: Install Light Panel LH & RH, bolted both sides with 12 positions.

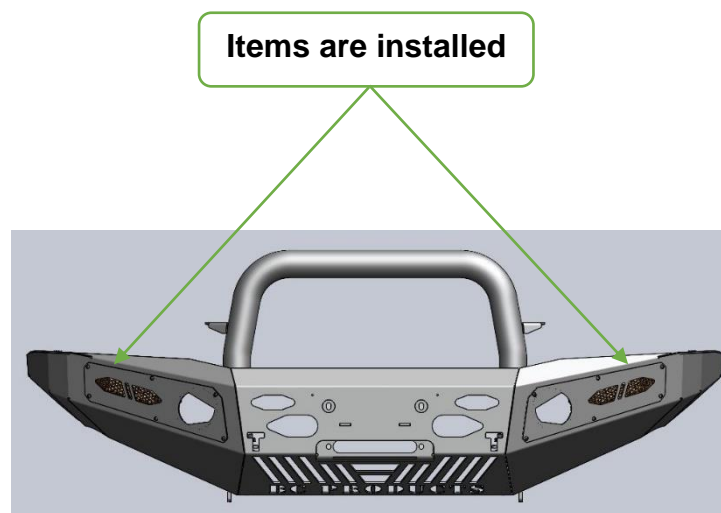
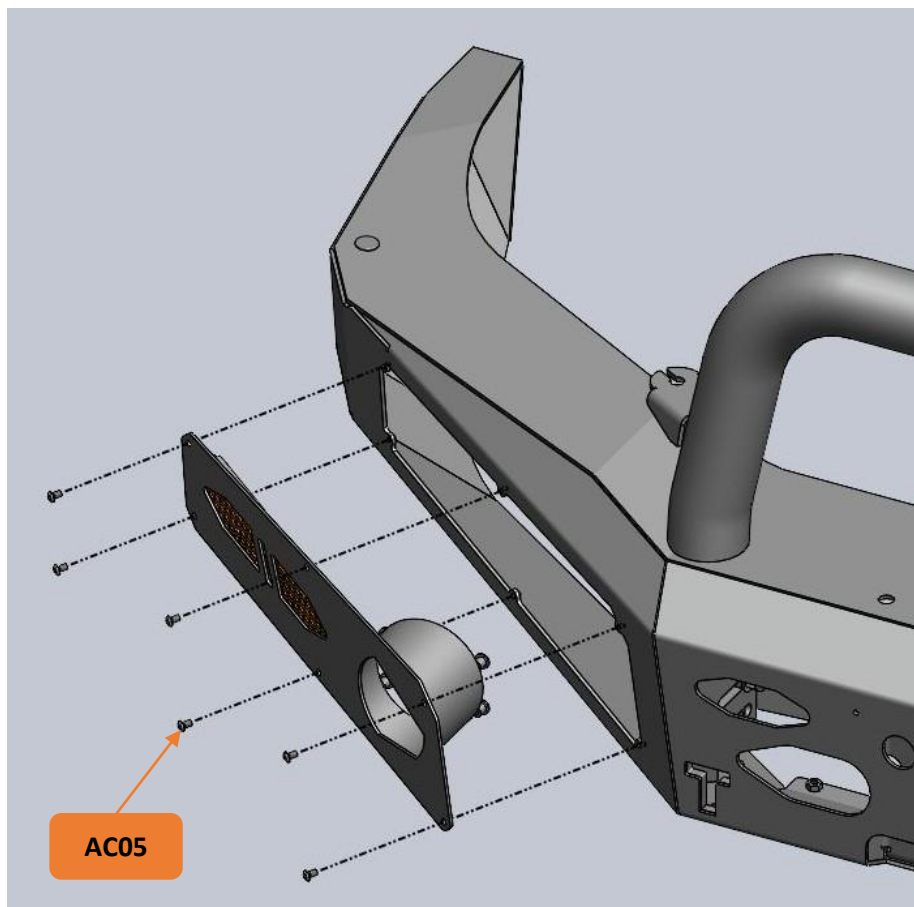

AC05 x 12 pcs : M6 x 10mmL x P1 Steel Hex socket (allen Key) & Domed Head Bolt

Bolt Tightening Torque: 10(Nm)

WI-006-R2

STEP 5: Install License Plate, bolted with 2 positions.

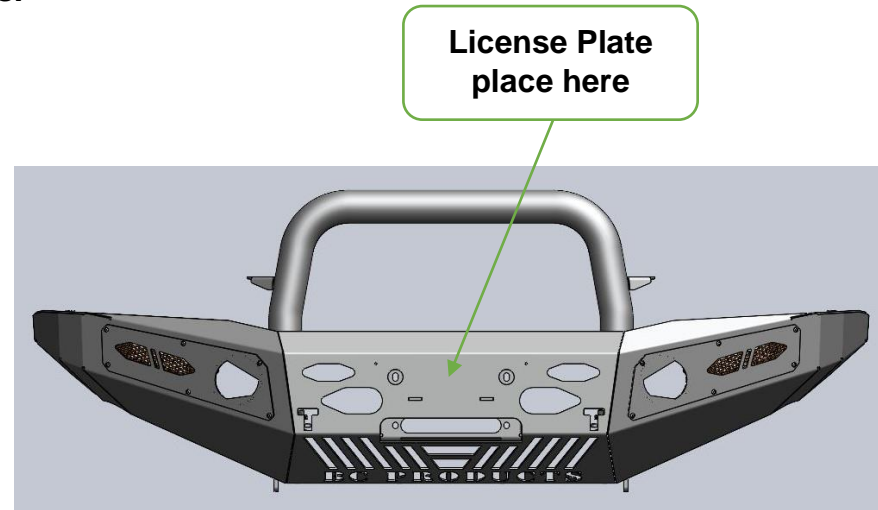
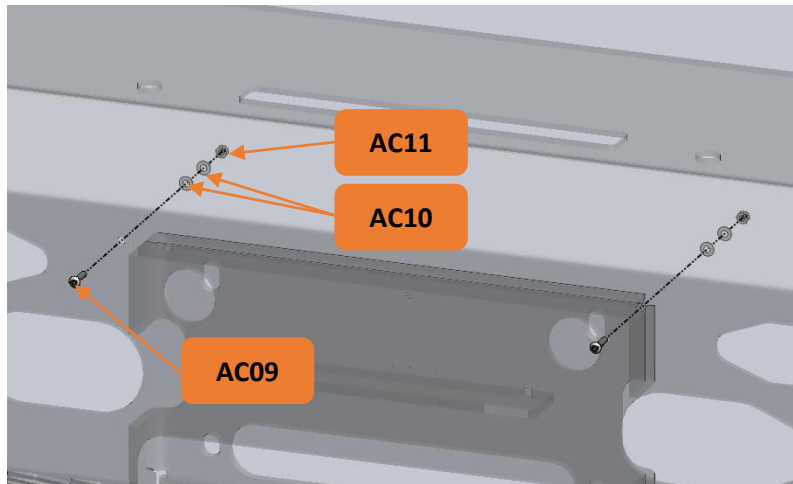

AC09 x 02 pcs : M4 x 15mmL x P0.7 Hex socket (allen Key) & Domed Head Bolt

AC10 x 04 pcs : Steel Flat Washer M4 x 4.3mmID x 9mmOD x 0.8mmT

AC11 x 02 pcs : Nyloc Nut M4 x P0.7

Bolt Tightening Torque: 3(Nm)

Recommendation:

Due to the variation of vehicle chassis some shimming may be required by using the extra washers supplied (**AC04**) to assist in lining up the bar where required.

----- END -----